

TWO-LINE DISTRIBUTOR

DLDT, DLDT-P

APPLICATION

DLDT and DLDT-P distributors are a lubricating element of two-line lubrication system applied for dosing lubricant into individual lubricated points. The distributors are applied for lubrication of various machines, machine groups and equipment, e.g. in metallurgy, cement works, sugar factories, power engineering, metallurgical plants etc.

DLDT distributors are supplied with regulation head, i.e. with possibility to adjust supplied lubricant dose, and DLDD-P distributors are supplied without regulation head, with fixed dose $3.0 \text{ cm}^3/\text{stroke}/\text{outlet}$.

DLDT and DLDT-P distributors are supplied with various number of outlets - 1 to 8. Individual types and other series of two-line distributors (e.g. DLDA, DLDC, DLDF, ZVM) can be combined mutually in a central lubrication circuit, so a high variability of nominal doses can be reached and further can be adjust during system operation.

DESCRIPTION

A distributor is based on a body in which 1 to 4 functional units are placed with respect to appropriate types. Every functional unit consists of a distributing piston (slider), delivery piston (dosing lubricant into the point to be lubricated), regulation head, signalling pin (regulation rod), regulation screw and 2 to 8 outlets that can be provided with full outlet piping. Regulation head of DLDD-P distributors is replaced by plug. The inlet piping is connected to the distributor through the complete inlet connection. There are two anchor holes for 8 mm diameter screws in the distributor body.

OPERATION

The two-line distributor is connected into the circuit of a two-line lubrication system. For a distributor to function, it is essential to alternate the pressure in pipe lines, which is provided by the working function of the two-line lubricating pump. When the lubricant is supplied into one branch, the distributing piston is shifted on into a limit position. The lubricant gets under the delivery piston by opening a connecting channel. The delivery piston moves into the other limit position and simultaneously forces out the lubricant through the interconnecting channel around the distributing piston into the outlet. The whole working cycle is repeated in the opposite direction after supplying the pressure to the other branch and relieving the first branch. Two strokes of a distributor are needed for the lubrication of all the lubricated points included in the two-line lubrication system. Nominal dose adjustment (only for DLDD distributors) is performed by means of an adjusting screw in the regulation head. By means of this adjusting screw the stroke of delivery piston is limited through the regulation rod. If the adjusting screw is fully tightened, the outlet is adjusted to minimum flow rate. An odd number of outlets is attained by plugging one of the functional unit outlets and taking out its distribution screw (with distributors already supplied with an odd number of outlets made by supplier). In this case a doubled nominal dose is supplied into the opposite outlet, which can be adjusted by an adjusting screw according to requirements. This fact allows the variability of nominal doses of lubricant from the outlet to be extended. If there is a requirement for much more different nominal doses of lubricant from the outlets of one DLDD or DLDD-P distributor, the dose can be doubled or tripled by using connecting bridges. This special requirement must be arranged through the supplier.

SERVICE AND MAINTENANCE

DLDD, DLDD-M, DLDD-P distributors are mounted in any position. During the assembly it is advisable to ensure easy access to the adjusting screws for the control of nominal dose. The distributors are fixed directly to the machine foundation by means of M8x70 mm screws or by a welded-on clamp. The clamp and anchor bolts are not part of the delivery.

After the distributor is mounted to the chosen place the inlet piping is connected and the lubricant passed through. The connection of the distributors to the piping should always be made in the same way, i.e. the same inlet piping, e.g. upper one, should be connected to the same pipe line. The distributor is adjusted for maximum dose. When the lubricant leaves the outlets without air bubbles, the outlet piping can be connected. It is recommended to adjust the doses only during operation. The distributors require no further service except to check connections for leakage from time to time.

TECHNICAL DATA

Maximum working pressure	400 bar	
Working pressure	350 bar	
Minimum working pressure	10 bar	
Nominal output	3.0 cm ³ /stroke/outlet	
Regulating range of nominal output	0 to 100%	
Number of outlets	DLDT 2-1	1
	DLDT 2-2	2
	DLDT 4-3	3
	DLDT 4-4	4
	DLDT 6-5	5
	DLDT 6-6	6
	DLDT 8-7	7
	DLDT 8-8	8
Inlet pipe union	G3/8"	
Outlet pipe union	G1/4"	
Lubricant	grease	max. NLGI-2
	oil	min. 50 mm ² /sec.
Temperature of working environment	-25 to 80°C	
Weight	1.3 to 4.6 kg (depending on execution)	

NOTE:

It is possible to supply DLDT and DLDT-P two-line distributors with complete assembled inlet and outlet connections according to customer's request. It is necessary to indicate the specification in order or a specification on packing list might be used (see User's guide).

DLDT 2-2

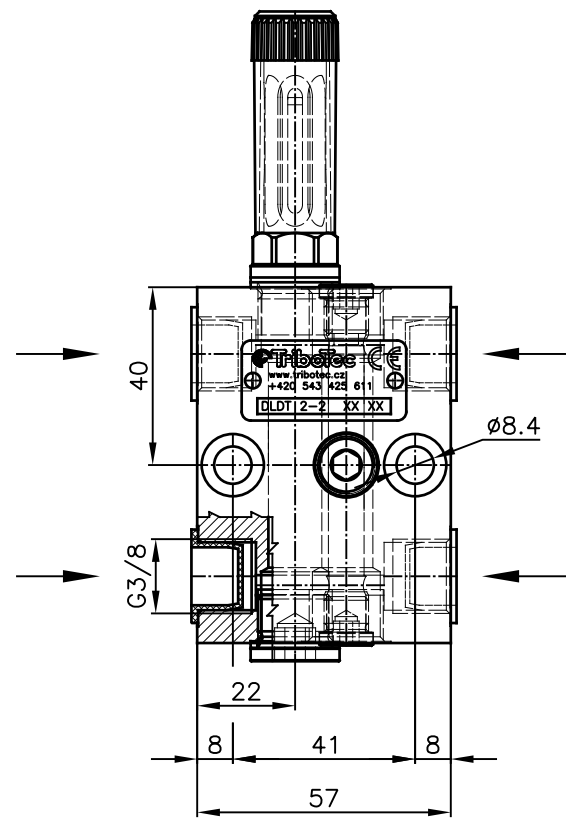

DLDT 4-4

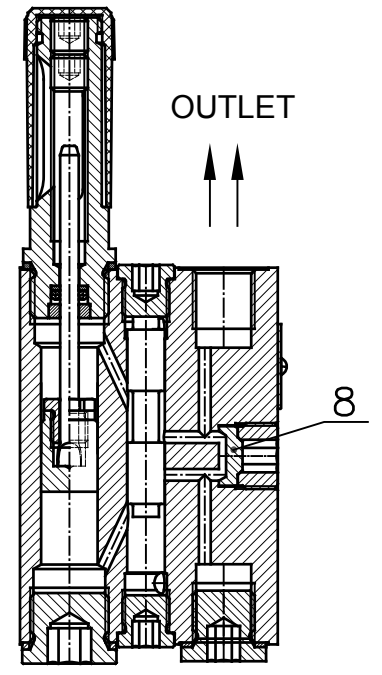
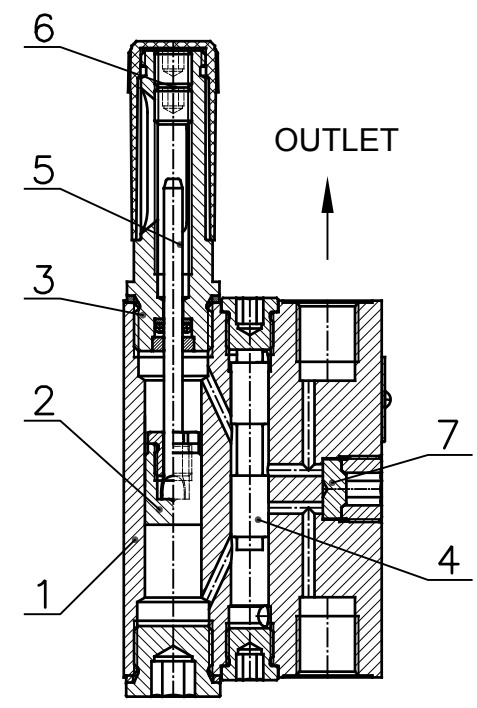
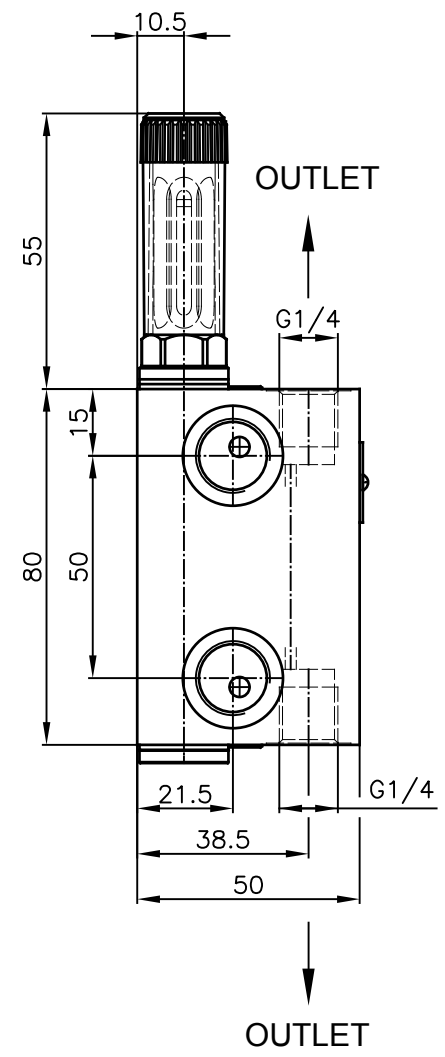
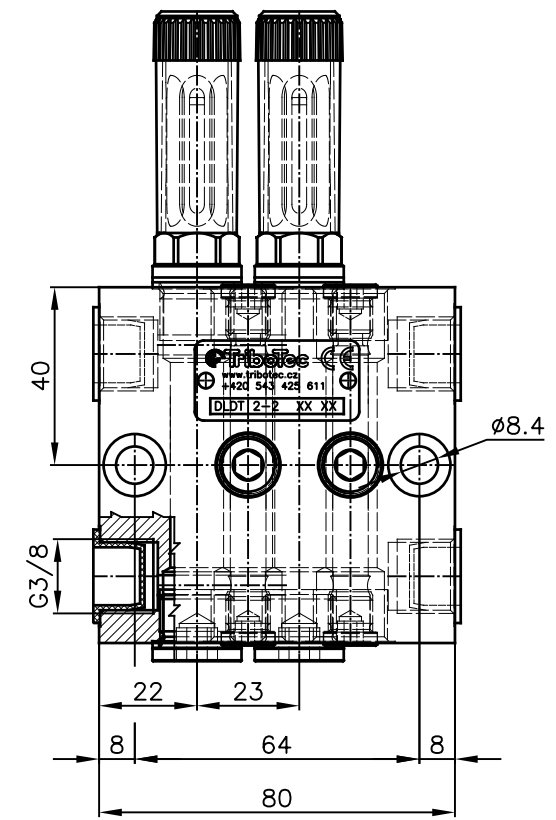

DLDT 6-6

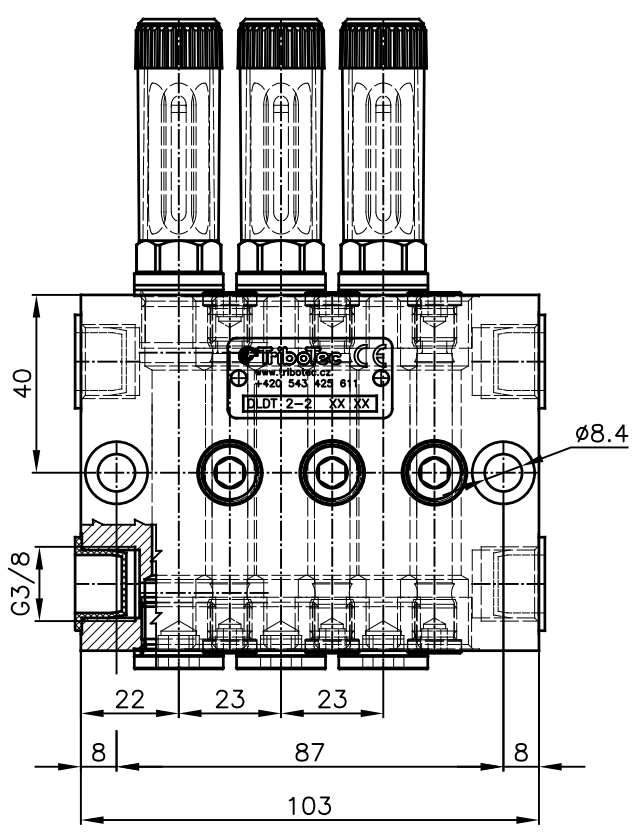

DLDT 8-8

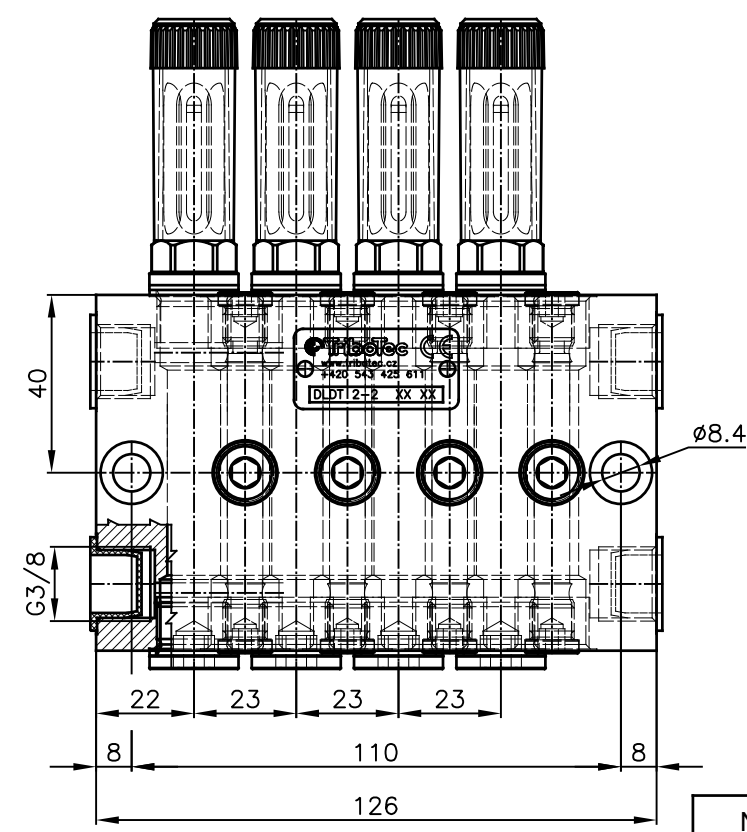

Type	Code
DLDT 2-2	9 52 1080
DLDT 4-4	9 52 1081
DLDT 6-6	9 52 1082
DLDT 8-8	9 52 1083

Type	Code
Double outlet adaptor	52 1089
Single outlet adaptor	52 1090

Pos	Name
1	Distributor body
2	Metering piston
3	Regulatory head
4	Servo piston
5	Indicator rod
6	Regulating screw
7	Double outlet adaptor
8	Single outlet adaptor

Name	TWO-LINE DISTRIBUTOR		s.r.o. Košuličova 4 Brno www.tribotec.cz +420 543 425 611
Type	DLDT		
Code			

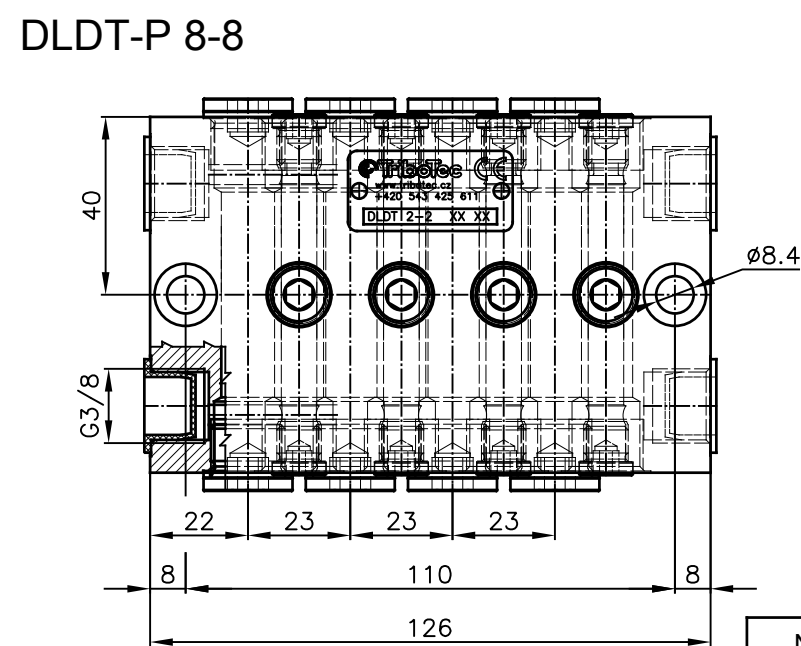
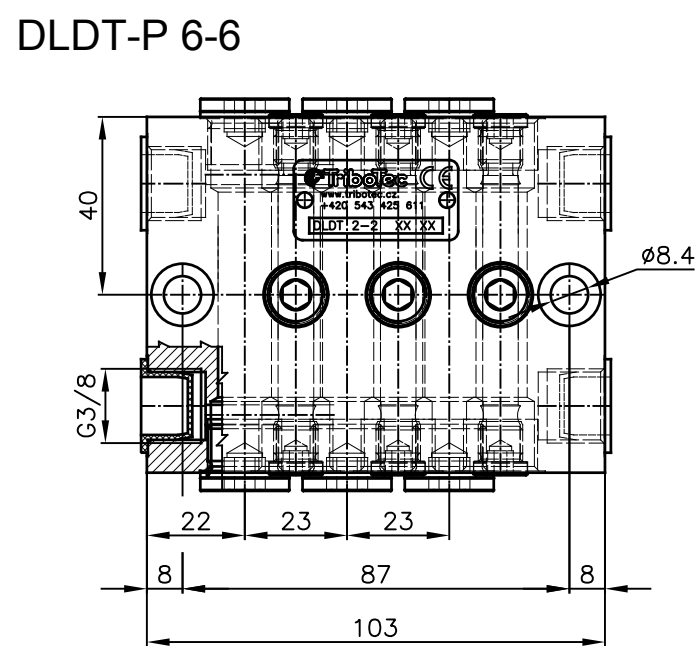
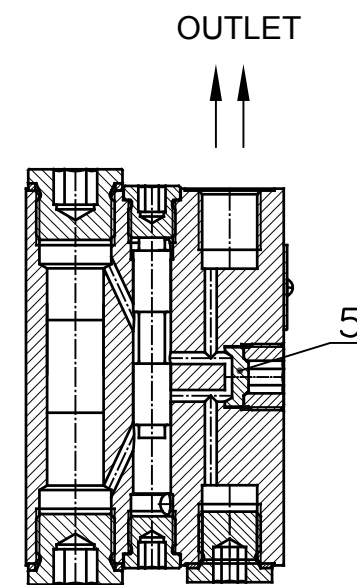
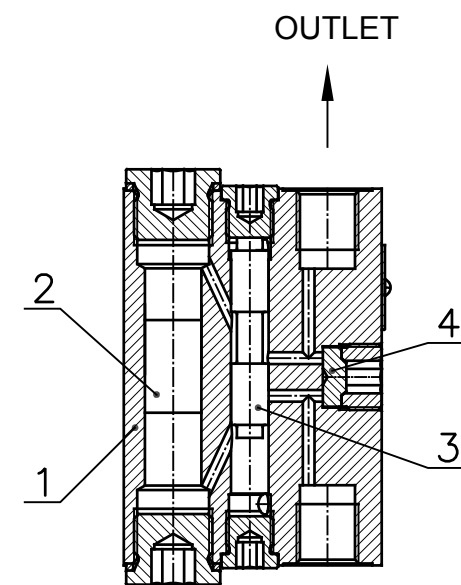
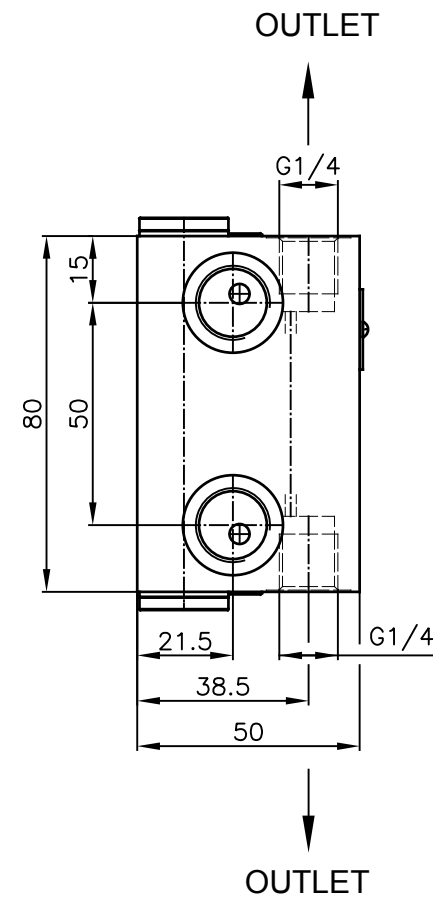
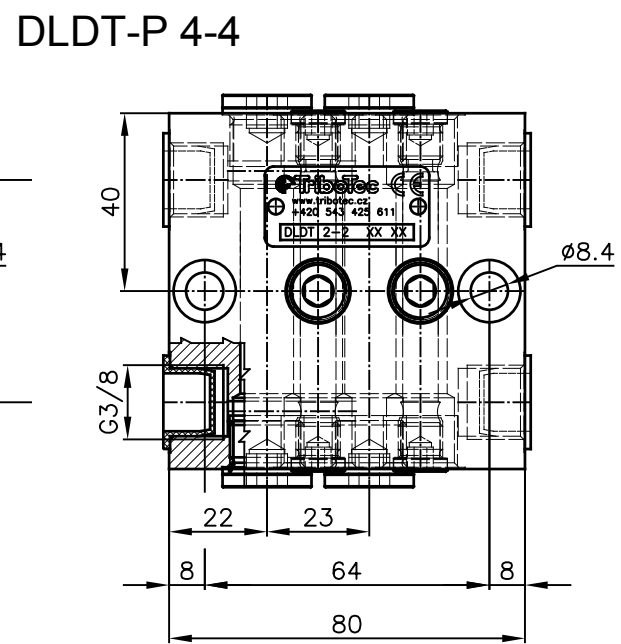
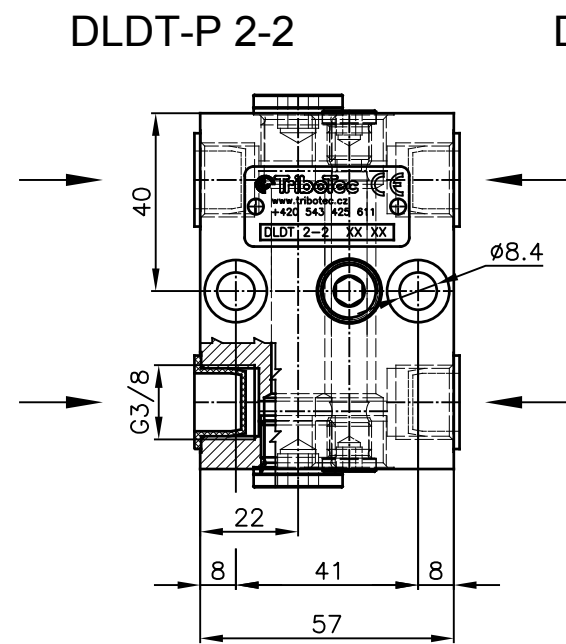

Type	Code
DLDT-P 2-2	9 52 1095
DLDT-P 4-4	9 52 1096
DLDT-P 6-6	9 52 1097
DLDT-P 8-8	9 52 1098

Type	Code
Double outlet adaptor	52 1089
Single outlet adaptor	52 1090

Pos	Name
1	Distributor body
2	Metering piston
3	Servo piston
4	Double outlet adaptor
5	Single outlet adaptor

Name	TWO-LINE DISTRIBUTOR		Tribotec s.r.o. Košuličova 4 Brno www.tribotec.cz +420 543 425 611
Type	DLDT-P		
Code			